

MANUFATURER / MARKETING AND ADVERTISING: MyWam Sp. z o.o.

CE



VILA

ILLUSTRATIVE PHOTO



OPERATION AND MAINTENANCE MANUAL

Edition 2 / 2025-02-10

Special needs stroller VILA

THIS IS MEDICAL DEVICE.

USE IT ACCORDING TO THE INSTRUCTION MANUAL OR LABEL.

PURPOSE OF THE MANUAL

Operating manual is designed for people who directly care of children with disabilities (childcare assistants, parents, guardians), which will be transported in a stroller. It is also intended for doctors and physiotherapists operating the stroller.

ATTENTION! Before using the stroller, each User is obliged to read the manual and act in accordance with its guidelines.

ATTENTION! In the event of any medical incidents related to the presence of the VILA stroller, the Manufacturer must be immediately notified in writing by contacting it via registered letter or e-mail with acknowledgment of receipt.

Manufacturer contact details:

- postal address: MyWam sp. z o.o., Lwowska 34, 41-500 Chorzów, Poland
- contact phone number: +48 32 733 11 31
- e-mail address: mywam@mywam.eu



User and maintenance manual version: **EN, Edition 2 / 2025-02-10**

The manual was translated using Microsoft Translator.

MyWam sp. z o.o. reserves the right to make technical and commercial changes to the contents of the Operation and Maintenance Manual without prior notice. Each change will be determined by the date the instructions were last updated. The electronic version of the manual is available at www.mywam.eu

ATTENTION! Pictures given in the operating manual are for reference only and can vary from the purchased model.

MyWam sp. z o.o. has implemented a quality management system compliant with the ISO 13485 standard in the design, production and sale of class I medical devices.. System certified by LL-C (Certification).



ISO 13485

LL-C (Certification)



TABLE OF CONTENTS

PURPOSE OF THE MANUAL	2
1. PURPOSE AND INDICATIONS FOR USE	5
2. PLATES.....	5
3. SYMBOLS DESIGNATION.....	5
4. IMPORTANT INSTRUCTIONS AND SAFETY RULES.....	6
5. GENERAL CONSTRUCTION OF THE STROLLER	7
6. STROLLER FUNCTIONS	9
6.1. Unfolding the stroller frame	9
6.2. Folding the frame of the stroller	10
6.3. Transport lock. Putting on and taking off the transport lock.....	11
6.4. Front swivel wheels. Front wheels directional lock.....	11
6.5 Rear wheels. Assembly and removal of rear wheels on axle.....	12
6.6 Push handle for the stroller	13
6.7 Central brake.....	14
6.8 Tilt foot.....	14
6.9. Footrest.....	15
6.10. Seat depth adjustment.....	16
6.11. Backrest angle adjustment.....	16
6.12. Five-points belt	18
6.13. Safety barrier	19
6.14. Adjustable canopy with window.....	19
6.15. Abduction and stabilization belts.....	20
6.16. Headrest pads	21
6.17. Torso pads.....	22
6.18. Hip pads	23
6.19. Wedge.....	24
7. ADDITIONAL EQUIPMENT.....	25
7.1. Shopping basket.....	25
7.2 Therapy table	25
7.3. Travel bag.....	26
7.4. Sunshade umbrella.....	26
7.5. Winter gloves	27
7.6. Sleeping bag for legs (to be placed on the safety barrier).....	27
7.7. Mosquito net (attached to adjustable canopy with window)	27

7.8. Rain cover (attached to adjustable canopy with window)	28
8. TECHNICAL SPECIFICATIONS OF THE VILA STROLLER.....	28
8.1. Material composition of the stroller	29
9. DELIVERY AND TOOLS	29
10. ASSEMBLY AND DISASSEMBLY OF THE STROLLER	29
11. PREPARATION FOR USE.....	30
12. MOVING THE STROLLER.....	30
13. GETTING IN AND OUT OF A STROLLER.....	31
14. CORRECT POSITION IN A STROLLER	31
15. USE OF THE STROLLER.....	31
16. MOVING ON INCLINED SURFACES	31
17. OVERCOMING THRESHOLDS OR CURBS.....	31
18. TRANSPORT IN THE CAR AND IN OTHER VEHICLES.....	32
19. USE OF A STROLLER AS A SEAT IN A MOTOR VEHICLE.....	32
20. CLEANING AND CARE	35
21. STORAGE OF THE STROLLER.....	35
22. SERVICE AND PERIODIC INSPECTIONS	36
23. UTILIZATION	37
24. COMPLIANCE WITH THE REQUIREMENTS MEDICAL DEVICE	37
25. LIST OF AUTHORIZED SERVICE POINTS	38
26. WARRANTY CARD	39
27. NOTES.....	40

1. PURPOSE AND INDICATIONS FOR USE

The VILA special needs stroller is a class I medical device indicated for use by those disabled children who, due to their health condition, cannot walk, stand or sit down independently. The device is intended for transporting and moving the above-mentioned persons in a sitting or semi-recumbent position. Clinical indications include cerebral palsy, meningo-spinal hernia, dystrophies, paresis, etc.

The product is intended for users 80-130 cm height and up to 40 kg of weight. The product should be used in accordance with the recommendations of the attending physician or physiotherapist.

Contraindications:

In case of contraindication to the sitting position and/or passive upright positioning, the adjustment of the stroller should be consulted with a physiotherapist or attending physician.

2. PLATES

Nameplate





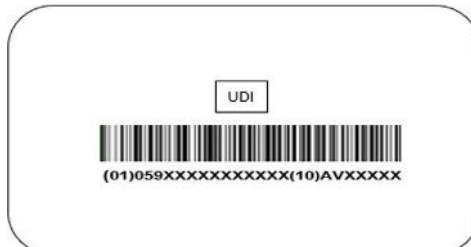



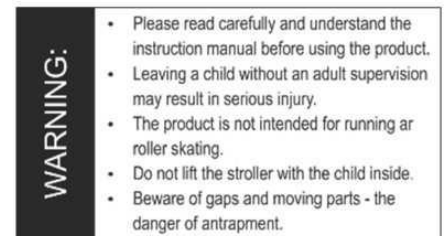

UDI code plate



Warning plate



3. SYMBOLS DESIGNATION

	Product serial number		The manufacturer's name
	Permitted total user weight		The product is a medical device
	Production date		DESCRIPTION "WARNING!" and the symbol in this manual are used to enhance the reader's attention to the content marked with this sign. Non-compliance with content marked with this description may endanger the health and safety of the user and accompanying persons, and may also damage the product.
	Conformity assessment mark according to applicable European regulations and directives		
	Warning about proceeding in accordance with the product Operation and Maintenance Manual		

4. IMPORTANT INSTRUCTIONS AND SAFETY RULES

- It is prohibited to use the stroller in a manner for which it is not intended.
- The product contains small parts which can be dangerous if swallowed by a child!
- It is forbidden to place additional weight on the stroller, in particular to place additional weight on the back of the backrest, e.g. a rucksack or bag. This may cause the VILA stroller to tip over and injure the user! This does not apply to original accessories dedicated to the VILA stroller that do not exceed the permitted load. All additional components attached to the stroller affect the stability of the stroller.
- **ATTENTION:** Never adjust the pram when the user is not secured with the five-point belts.
- **ATTENTION:** When using the stroller and when folding and adjusting the mechanisms, particular care should be taken with moving parts, as there may be a danger of the user/carer's body parts becoming trapped and/or pinched in the openings/gaps between components.
- **ATTENTION:** Depending on the adjustments made - concerning the setting of the push handle, backrest height adjustment, backrest angle adjustment, seat depth adjustment, seat angle adjustment, footrest angle adjustment and footrest setting - this pushchair may exceed the recommended maximum dimensions.
- **NOTE:** When passing through doors or similar constrictions that restrict the direction of travel of the stroller, ensure that there is sufficient space on both sides of the stroller to prevent hands or other parts of the body from being trapped, as well as to prevent damage to the stroller.
- **NOTE:** The temperature of the stroller may increase when the stroller is exposed to sunlight.

WARNING!



- Never leave your child unattended in a stroller, as it risks danger!
 - This product is not suitable for running or skating or rollerblading.
 - The stroller is not intended as a seat in a motor vehicle.
 - Beware of crevices and moving parts - risk of jamming.
 - Do not carry the pushchair with the child.
 - The pushchair is packed in a plastic bag. Keep out of reach of babies and small children.
-
- **ATTENTION:** It is forbidden to use the stroller if the technical condition of the product or its single component raises doubts in the user's mind or is clearly incorrect, in which case it must not be used. In such a situation, it is advisable to contact the Seller urgently for advice.

5. GENERAL CONSTRUCTION OF THE STROLLER

Basic equipment



- 1- Headrest pads
- 2- Five-points belt
- 3- Wedge
- 4- Adjustable seat
- 5- Front wheels directional lock
- 6- Front swivel wheels
- 7- Torso adjustable pads
- 8- Hip pads
- 9- Abduction and stabilization belts

- 10- Backrest angle adjustment mechanism
- 11- Safety barrier
- 12- Adjustable footrest with straps
- 13- Rear wheels, solid
- 14- Adjustable canopy
- 15- Push handle
- 16- Frame folding mechanism
- 17- Transport lock
- 18- Tilt foot
- 19- Central brake

Additional equipment



- 1- Sunshade umbrella
- 2- Therapeutic table
- 3- Sleeping bag for legs
- 4- Winter gloves

- 5- Rain cover
- 6- Shopping basket
- 7- Mosquito net
- 8- Travel bag

6. STROLLER FUNCTIONS

6.1. Unfolding the stroller frame



Pull down the transport lock



Pull up the push handle



While holding the tilt foot with your foot, pull the push handle upwards



6.2. Folding the frame of the stroller



1

Position the front wheels as follows



2

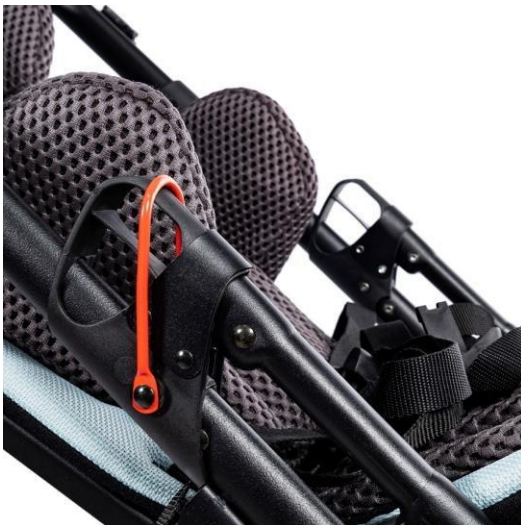

3



4

Pull the handles on both sides of the frame upwards at the same time



5



6

Attach transport lock



Correct positioning of the front wheels when the stroller is folded

6.3. Transport lock. Putting on and taking off the transport lock



Lock applied



Removed lock

6.4. Front swivel wheels. Front wheels directional lock

Wheel assembly

1



2



Wheel dismantling



Locking the front wheels



Unlocking the front wheels



6.5 Rear wheels. Assembly and removal of rear wheels on axle

Wheel assembly



Wheel dismantling



Assembly of axles



Dismantling of axles



6.6 Push handle for the stroller

Angle adjustment mechanism for the push handle



Press the buttons on both sides and change the angle of the push handle.

Angle adjustment of the push handle



6.7 Central brake



The central brake is used only and exclusively to completely lock the wheels - it does not have a dynamic braking function.

NOTE! The brake condition should be checked regularly and any dirt and mud removed.

6.8 Tilt foot



Using the tilt foot it easier to drive the stroller up small thresholds or curbs.

6.9. Footrest

Footrest height adjustment



Minimum height



Maximum height

Footrest assembly



Press the marked buttons and hook the footrest onto the pins on the frame.

Folding footrest



Note: To fold the footrest, it must be fitted at the maximum adjustment height.

Note: During transport, storage, rehabilitation, getting in and out of the wheelchair, the footrest must be folded down.

6.10. Seat depth adjustment



Minimum seat depth



Maximum seat depth

Pull the seat towards you or slide it in.

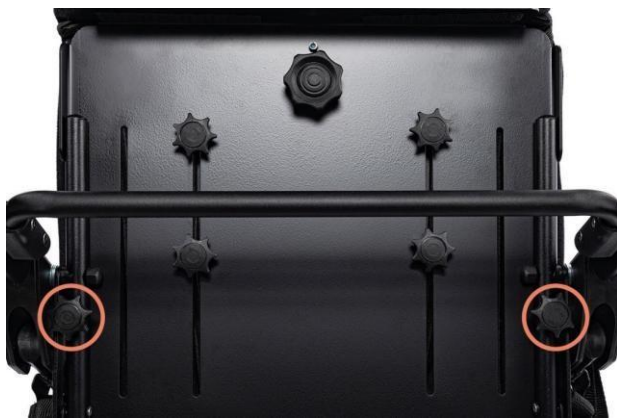

NOTE: Use the marked knobs to adjust the seat depth.

Once the seat depth is set, turn the knobs.

6.11. Backrest angle adjustment

Backrest tilt adjustment



Seated position



Semi-recumbent position

Note: Every time the angle of the backrest is changed, the length of the five-points belt must be readjusted.

Backrest tilt adjustment – semi-reclining position



Backrest tilt adjustment - sitting position



3



4



6.12. Five-points belt



Belt adjustment

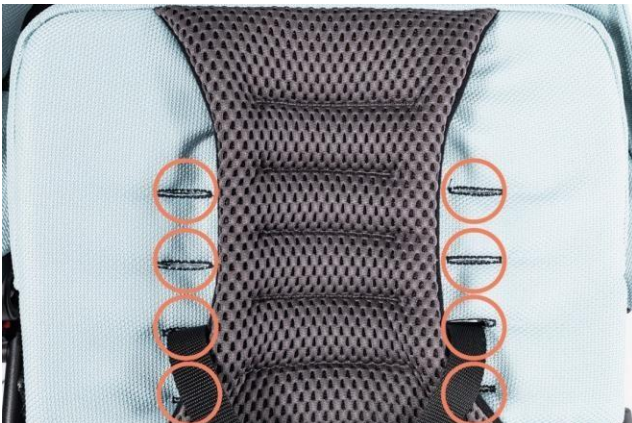

6.13. Safety barrier



Barrier installation



Demounting the barrier



Press the button on both sides and insert or slide out the railing.

6.14. Adjustable canopy with window

Mechanism for mounting the canopy to the frame of the pushchair



Slide the attachment on the canopy into the attachment on the frame of the stroller.

Removable by means of a red button on the outside of the canopy attachment on both sides.

Changing the size of the canopy area



6.15. Abduction and stabilization belts

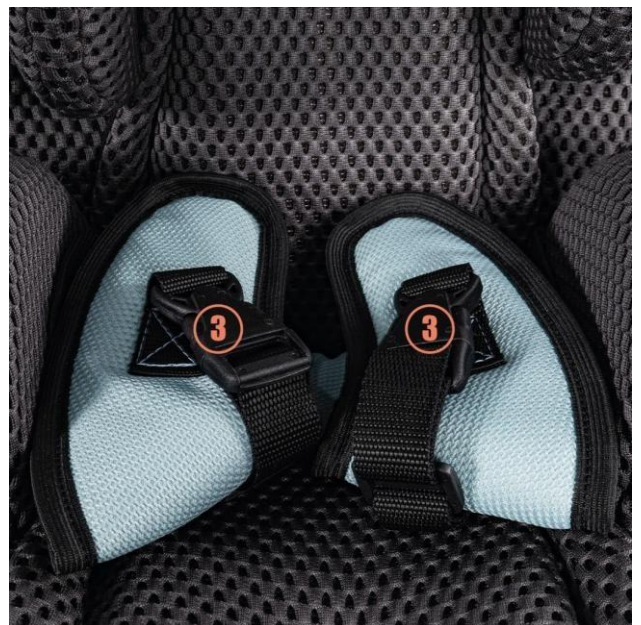

6.16. Headrest pads

Pads adjustment



Backrest width adjustment



Height adjustment of the pads



6.17. Torso pads

Pads adjustment

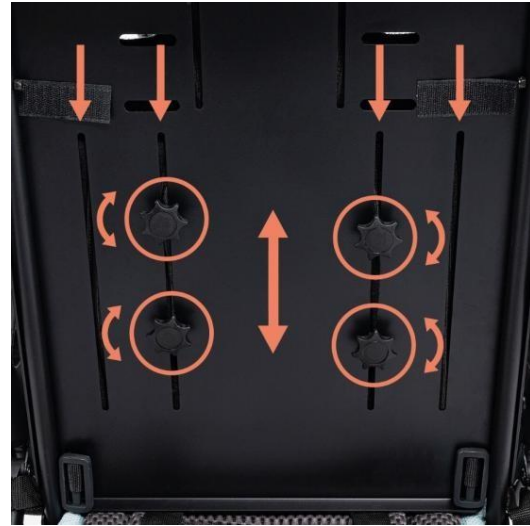

Backrest width adjustment



Height adjustment of the pads



6.18. Hip pads

Pads adjustment

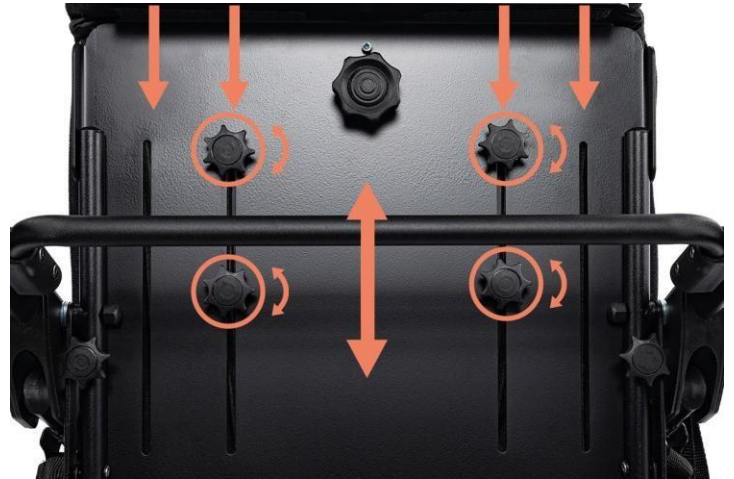

Seat width adjustment

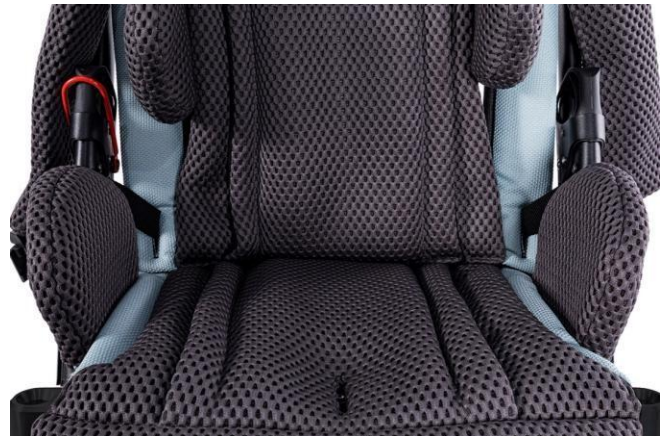

Pads depth adjustment



6.19. Wedge

7. ADDITIONAL EQUIPMENT

7.1. Shopping basket



Maximum load is 3kg.

7.2 Therapy table



Maximum load is 3kg.

Table assembly/disassembly

Changing the table angle



7.3. Travel bag



Maximum load
bag is 2kg.



7.4. Sunshade umbrella



7.5. Winter gloves



7.6. Sleeping bag for legs (to be placed on the safety barrier)



7.7. Mosquito net (attached to adjustable canopy with window)



7.8. Rain cover (attached to adjustable canopy with window)



8. TECHNICAL SPECIFICATIONS OF THE VILA STROLLER

stroller length	97-108 cm
width of the stroller	61 cm
height of the stroller	122 - 135 cm
total weight	21 - 24 kg
effective seat depth	23/33 cm
seat width	18*/39 cm
backrest height	66 cm
backrest width	18* / 39 cm
distance between footrest and the seat / number of adjustments	21-40.5 / 3 positions
length of the stroller folded for transport	93 cm
width of the stroller folded for transport	61 cm
height of the stroller folded for transport	40-52* cm
capacity of the shopping basket	2 kg
carrying capacity of the bag	2 kg
maximum patient weight	40 kg
maximum patient height	80-130 cm
seat plane angle / number of adjustments	approx. 24° / 1 position
backrest tilt angle / number of adjustments	approx. 20°-59° / 2 positions
footrest angle / number of adjustments	approx. 37° / 1 position

NOTES:

*) values given with pads

Measurement value tolerance +/- 20mm, +/- 1.5kg, +/- 1°

The manufacturer reserves the right to make changes to the technical parameters

8.1. Material composition of the stroller

Material composition of the stroller: powder-coated steel and aluminum, fabrics 100% polyester and plastic (PP, PVC, PA, PU).

9. DELIVERY AND TOOLS

The following items should be included in the original packaging:

- Folded pram frame including seat and backrest, footrest, wheels, canopy,
- Additional equipment according to the order,
- User manual with warranty card.

Before use:

- Make sure that the package has not been damaged. If it is found that the package is damaged, then at the presence of the courier, unpack the goods and check whether none of the stroller elements hasn't been damaged.
- On the basis of the specification check the package content (in case of any missing elements contact your Seller).

No tools are required to assemble and dismantle the VILA stroller.

10. ASSEMBLY AND DISASSEMBLY OF THE STROLLER

- **Assembly of the stroller.** The product, pre-packed in the original carton, is already pre-assembled.

Complete the assembly by performing the following steps:

- a) mount the front wheels,
- b) mount the rear wheels on the axle,
- c) unfold the frame of the pushchair including the seat by adjusting the parameters:
 - activate/deactivate the directional lock on the front wheels,
 - adjust the height and angle of the push handle,
 - adjust the angle of the backrest,
 - adjust the length of the five-points belt,
 - adjust the height of the footrest,
 - adjust the abduction and stabilization belts,
 - install a safety barrier,
 - adjust the canopy with window,
 - adjust the head pads, thoracolumbar and hip pads,
 - install and adjust the wedge,
 - put on a shopping basket,
- d) fit the appropriate equipment and adjust the parameters, for example:
 - install a therapy table,
 - install a tour bag,

- install selected items of equipment dedicated to the seasons: sleeping bag for legs, winter gloves, mosquito net, rain cover, sun umbrella.
- **Dismantling the stroller:**
 - a) remove additional equipment,
 - b) fold the footrest and frame of the pushchair,
 - c) unfasten the rear wheels,
 - d) fold the stroller by closing it with the transport lock.

11. PREPARATION FOR USE

Before using the stroller, you should:

- Check that the stroller frame has been correctly unfolded and that the frame folding mechanism has been correctly closed (locked).
- Check that the seat has been correctly mounted to the stroller frame and that the seat attachment mechanism to the stroller frame has been correctly closed (locked).
- Correctly make all adjustments and adjust the stroller to the child's needs, including setting the appropriate depth of the therapeutic seat, the appropriate inclination of the therapeutic seat and the inclination of the backrest, set the appropriate inclination of the footrest, adjust the appropriate length of the five-point belts. Check that all adjustment elements are properly seated and secured.
- Check that the stroller upholstery is dry.
- Secure the child with all available stabilizing elements, such as: five-point belts, narrowing and shallowing inserts, abduction and stabilizing belts, wedge, footrest, footrest straps, safety barrier or therapeutic table. This is to protect the child from falling out and sliding out of the stroller and to protect the child's feet from falling off the footrest. Make sure that all adjustments made earlier are appropriate and safe for the child.
- Make sure that the child is not placed in the stroller without clothing that covers the body in places of contact with the stroller upholstery. This is to prevent abrasions to the child's body and for the child's hygiene.
- In the case of children who have problems with holding urine, a special oilcloth should be placed on the stroller seat, which can be purchased in pharmacies or medical stores.
- In the case of using any additional aids such as venflons, drains, bags, catheters, etc., make sure that they are well secured against falling out, tearing out, squeezing and do not interfere during use of the stroller.

12. MOVING THE STROLLER

The best way to carry a stroller is to push it using its wheels.

In cases where this is not possible (e.g. to transport the stroller in a car), for safety reasons, the stroller can be lifted and carried with both hands after previously removing the additional equipment to reduce the carrying weight and folding it.

When carrying or lifting the stroller frame, special care should be taken. The frame should be carried after it has been folded and the transport lock has been fitted.

Do not use additional equipment to carry the stroller - it may be damaged.

13. GETTING IN AND OUT OF A STROLLER

When getting in and out of the stroller, place the stroller as close as possible to a stable and safe place to which the user will be changing their position. After making sure that the central brake is engaged and the footrest is raised to avoid standing on it, the user may transfer.

WARNING! Do not stand on the footrest, as there is a risk of the stroller tipping over, injury to the user and risk of damage to the product.

Make ensure that when getting in or out of the stroller, the child and any other person do not stand on the footrest, as this may damage it and injure the user!

14. CORRECT POSITION IN A STROLLER

For safety and health reasons, it is recommended that the user has the hips and back positioned as close to the backrest as possible in order to support the spine evenly (optimal support of all parts of the spine so that no free space is created).

The thighs should be supported as much as possible, along their entire length, which is achieved by adjusting the depth of the stroller seat and the feet should rest on the footrest plate, which prevents slipping, maintains optimum muscle tone in the legs and transfers some of the weight from the upper body.

15. USE OF THE STROLLER

During use, always hold the push handle to prevent the stroller from rolling away.

Release the central brake while holding the push handle and push the stroller in a safe direction.

16. MOVING ON INCLINED SURFACES

Always position the stroller facing forward when climbing hills or ramps. Limit your speed on inclined surfaces and move as slowly as possible.

The person pushing the stroller must have appropriate strength to control the stability of the stroller.

Always keep in mind that the position of the centre of gravity of the stroller changes when traversing uneven or sloping terrain. In this case, special care must be taken and the stroller must be belayed.

When using ramps, ensure that the ramp is suitable, that the wheels of stroller are high enough to negotiate the ramp, that the stroller frame does not come into contact with the ramp and that a second person is provided to assist as there is a risk of the stroller tipping over, damaging the product and injuring the user.

17. OVERCOMING THRESHOLDS OR CURBS

When overcoming small obstacles (small thresholds, small curbs, etc.), use your foot to lock the tilt foot and push handle down and toward you to lift the front wheels of the stroller and carefully drive the front wheels over the obstacle. Then slowly pull the push handle up, away from the ground, to lift the rear wheels of the stroller and carefully drive the rear wheels over the obstacle.

18. TRANSPORT IN THE CAR AND IN OTHER VEHICLES

- Remove all accessories from the stroller and store them in a safe place. Fold the stroller and place it in the trunk.

If the dismantled stroller is not in the trunk of the car separate from the passenger compartment, the stroller frame must be carefully secured to the vehicle. For this purpose, you can use unused seat belts.

- In order to transport a stroller in other vehicles, such as trains, trams, buses, planes, ships, etc., it is necessary to ask the persons in charge of transportation in these means of transport about the conditions for safe travel to the destination with a stroller and relevant requirements.

19. USE OF A STROLLER AS A SEAT IN A MOTOR VEHICLE

THE STROLLER HAS PASSED THE DYNAMIC TEST ACCORDING TO ISO 7176-19:2022.



THE MAXIMUM WEIGHT OF THE USER TRANSPORTED ON THE VILA STROLLER MOUNTED IN THE CAR IS **40 KG.**



MYWAM SP. Z O.O. **NOT RESPONSIBLE** FOR PERSONAL INJURIES SUSTAINED AS A RESULT OF A ROAD ACCIDENT IN WHICH THE USER WAS STRAPPED IN A VILA STROLLER.



THE SAFETY OF A STROLLER USER LARGELY DEPENDS ON THE RESPONSIBILITY OF THE PERSON TRANSPORTING AND SECURING THE STROLLERS. IT IS CRUCIAL THAT THE PERSON IS PROPERLY TRAINED IN THE RULES AND REGULATIONS FOR PROPERLY SECURING STROLLERS IN THE VEHICLE AND FOLLOWS THESE GUIDELINES.



THE STROLLER, IN PARTICULAR ITS TRANSPORT HANDLES, MUST NOT BE MODIFIED.



IF POSSIBLE, THE ADDITIONAL EQUIPMENT OF THE STROLLER SHOULD BE PROPERLY SECURED AT THE STROLLER OR DISMANTLED AND SEPARATELY IMMOBILIZED IN THE VEHICLE SO THAT IN THE EVENT OF A COLLISION IT DOES NOT MOVE AND DOES NOT POSE A THREAT TO PASSENGERS.



THE STRUCTURE OF THE VILA STROLLER CAN BE DAMAGED AS A RESULT OF A ROAD ACCIDENT. BEFORE USING THE STROLLER AGAIN AFTER SUCH AN EVENT, IT IS NECESSARY TO CARRY OUT AN INSPECTION AT THE MANUFACTURER'S AUTHORIZED SERVICE CENTER.



A VILA STROLLER INSTALLED IN A VEHICLE ADAPTED TO TRANSPORT PEOPLE WITH DISABILITIES **DOES NOT PROVIDE** THE SAME LEVEL OF SAFETY AS SEATS PERMANENTLY FIXED IN THE VEHICLE. **IF THE USER'S CONDITION ALLOWS HIM TO BE TRANSFERRED TO THE CAR SEAT, IT IS RECOMMENDED TO USE THIS OPTION.**

IF YOU NEED TO TRANSPORT A USER IN A STROLLER, THE FOLLOWING RULES MUST BE OBSERVED:

- The vehicle should be adapted to transport passengers in strollers and equipped with dedicated attachment points.



DO NOT TRANSPORT YOUR CHILD IN UNSUITABLE VEHICLES!!

2. The wheelchair must be secured in the vehicle by a four-point belt system, providing frontal collision protection in accordance with ISO 10542.



Both the four-point belt fastening system as well as the chest and hip belts are not part of the VILA stroller equipment and are not added by the Manufacturer. They are the equipment of an adapted motor vehicle.

3. Preparation of the VILA stroller for installation in the vehicle:
 - Remove the following equipment of the stroller: adjustable canopy, therapy table, travel bag, rain cover, mosquito net, sleeping bag, winter gloves, sun umbrella.
 - Place the stroller in a seated position.
 - Adjust the five-point belts of the stroller according to the child's height.



The five-point belts with which the VILA stroller is equipped do not provide protection when transporting a child in the stroller with a motor vehicle. **THE FIVE-POINT BELTS OF THE STROLLER ARE USED ONLY TO STABILIZE THE PATIENT IN THE STROLLER.**

4. Installation of the VILA stroller in the vehicle:
 - Place the stroller, forward-facing, in a specially designated place in the vehicle. The use of the stroller in other configurations in the vehicle has not been studied.
 - Secure the stroller with the central brake.
 - Anchor the stroller to the vehicle using the four-point strap fastening system.
 - The straps should be attached to each of the 4 attachment points of the stroller protection separately, starting with the front and ending with the rear. The attachment points are marked with the following label:



Each of the belts should be as tightly fitted as possible to prevent the stroller from moving in the vehicle!

- Fasten the patient with a five-point belts with which the VILA stroller is equipped.
 - To reduce the risk of hitting your head and chest on vehicle components, use a lap belt and a chest strap.
5. Correct positioning of the chest and hip safety belts on the user:
 - The lap belt should be placed across the anterior part of the pelvis so that the angle of the lap belt is within the preferred zone from 30° to 75° relative to the horizontal, a steeper (larger) angle in the range shown in the photo below is desirable. The image shows the required range of angles for the lap belts anchored to the stroller, where the dimensions are given in millimeters and the character: "a" is the reference plane of the stroller.

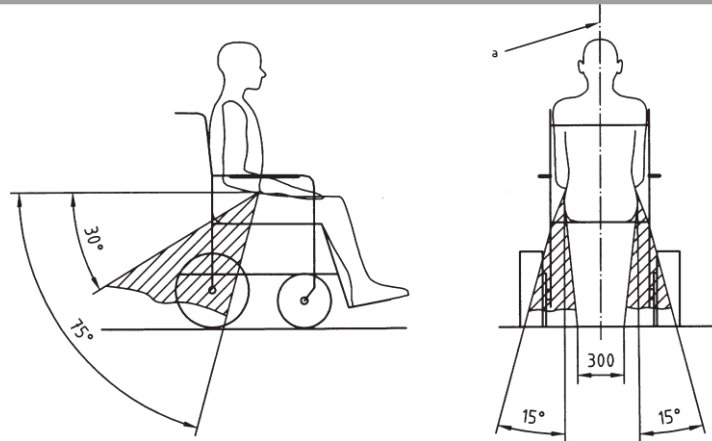

- Make sure that the lap and chest belts are not moved away from the body by elements of the stroller, e.g. pads or wheels.



- The hip belt should fit tightly to the front of the body, close to the hip joints.

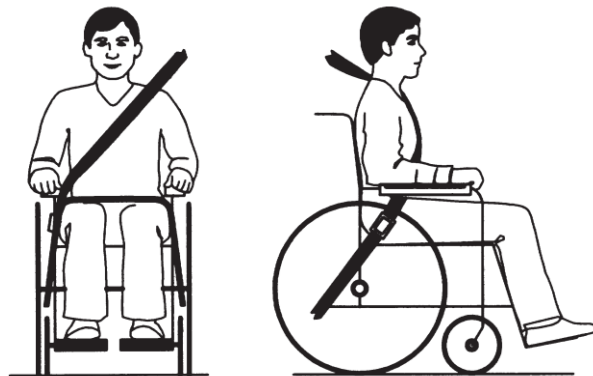

- The straps securing the upper torso should fit over the shoulder and across the chest as shown in the photo below. This photo shows that you should pay attention to:
 - Centerline,
 - center of the sternum,
 - the safety belts should be adjusted as tightly as possible, but ensure the comfort of the user,
 - the belt strap should not be twisted during use.

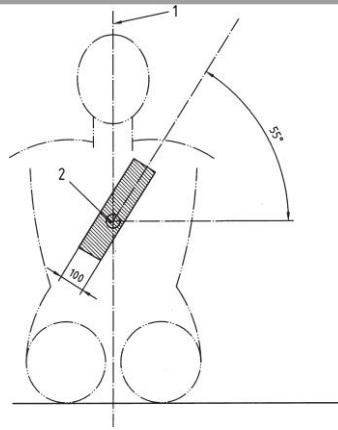

Do not attach the stroller with additional elements or accessories, i.e. wheels, footrest, push handle, etc.

20. CLEANING AND CARE

The upholstery can only be washed by hand at up to 30°C.

Stains should be removed as soon as they form on the surface of the stroller.

ATTENTION: Do not clean with chemicals containing solvents and bleach. The manufacturer is not responsible for damages caused by the use of unsuitable cleaning agents.

Make sure the product is always dry before use.

If using detergents dedicated to this type of material - follow the instructions of the detergent used.



Hand wash only



Do not bleach



Do not tumble dry
drum



Dry in position
horizontal



Do not iron

21. STORAGE OF THE STROLLER

Clean stroller should be stored in a clean, dry and well-ventilated room, preferably at 0-35°C. For long-term storage, additionally follow the steps described in point 21 "every one month".

22. SERVICE AND PERIODIC INSPECTIONS

For safe and trouble-free use of the stroller, it is necessary to regularly and thoroughly submit it to the inspections and servicing described below.

In a situation where the stroller user is not able to carry out the above-mentioned activities on their own, they should return the stroller to a specialized stroller service point or directly to the Manufacturer, who will properly carry out the inspection and necessary servicing activities. These activities may be subject to an additional fee.

NOTE: The Manufacturer is responsible for defects or technical damage to the stroller caused only when the stroller is operated correctly. Responsibility for the proper operation of the stroller rests with the Manufacturer only if all recommendations of the Manufacturer are strictly followed.

NOTE: The Manufacturer is responsible for the proper functioning of the stroller only if original parts and original accessories are used in it.

All repairs should be carried out in specialized authorized Services (see point 24) or directly at the Manufacturer. Repairs to the stroller performed by anyone other than an authorized Service or the Manufacturer will void the warranty. The Manufacturer is not responsible for injury or damage of the product that may be a consequence of repairs performed by persons other than the authorized Service or the Manufacturer.

Service should be performed:

- **Each time before using the stroller**
 - Check the efficiency of the central brake - After activating the central brake, both rear wheels of the stroller should be locked and cannot rotate.
 - Check the attachment of structural components - Inspect all mechanisms of the stroller and its moving parts, and in particular, pay attention to: correct mounting of the backrest to the frame of the stroller, proper mounting of the wheels, proper functioning of the five-point belts, correct functioning of the seat angle adjustment mechanism, correct functioning of the backrest recline mechanism and proper mounting of the footrest.
 - Check the condition of the tires - Check that the tires on all four wheels are not damaged or worn.
 - Inspection of solid frame parts, seat with backrest and footrest frame - Visually inspect the condition of the structural profiles. These components must not be damaged or cracked.
- **Every one month**
 - Cleaning of the stroller
 - Visual check of all the moving elements, bearings, adjusting mechanisms – lubricate with silicone grease.
 - Check all bolted connections for looseness.

23. UTILIZATION



Disposal and recycling: in accordance with country-specific regulations.

24. COMPLIANCE WITH THE REQUIREMENTS MEDICAL DEVICE

Medical Device Class I in accordance with Regulation (EU) 2017/745 of the European Parliament and of the Council of 5 April 2017 on medical devices. The manufacturer has issued a relevant declaration of conformity for the product, which can be found at www.mywam.eu

25. LIST OF AUTHORIZED SERVICE POINTS

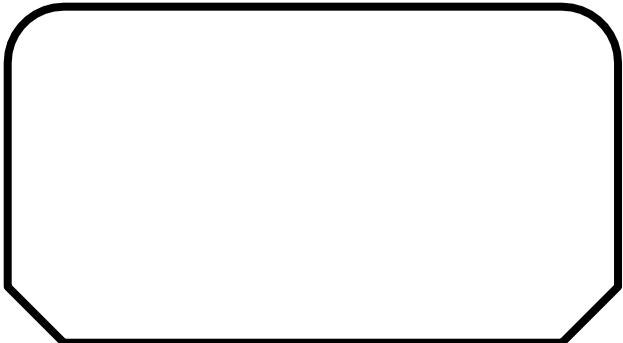
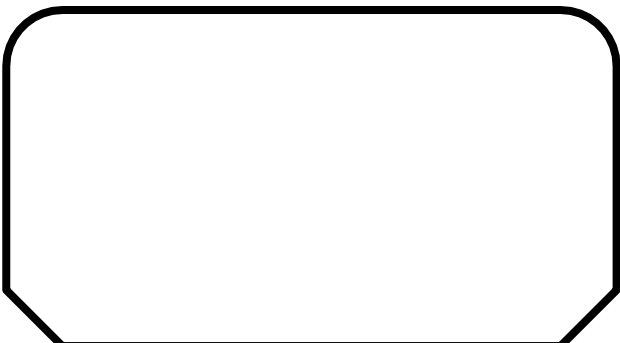
POLAND
MyWam sp. z o.o.
91 Wiosny Ludów Street, 40-373 Katowice, Poland
tel: +48 32 733 11 31
website: www.mywam.eu
email address: mywam@mywam.eu

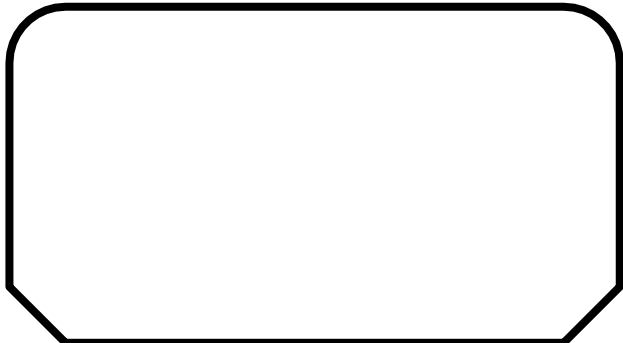

26. WARRANTY CARD

Series and number:

Purchase date: - -

Seller stamp and signature:

.....
.....
.....

Warranty conditions

- The seller grants the buyer a warranty for the purchased cart, for a period of 24 months, starting from the date of purchase.
- **The buyer complaining about the stroller should deliver the stroller to the Stroller in its packaging, clean (free of stains, additional equipment not belonging to the stroller, moisture, hair, etc.) along with the stroller components protected from damage.**
- **Damage caused by insufficient protection of the shipment of the stroller and its components is not subject to warranty repairs.**
- The claimant may not claim gratification if he mislabeled or improperly insured the shipment of the stroller and its components.
- The warranty period is extended by the time needed to repair the stroller.
- The activities provided for in the manuals, which the user is obliged to perform on their own and at their own expense, cannot be performed as part of a warranty repair.
- Unauthorized use of the stroller, inconsistent with these operating manual or inconsistent with the principles of correct operation will void the warranty.
- Making any structural changes to the stroller will void the warranty (either in the particular segment where changes have been made or in full).
- Damage to the stroller caused by: improper operation, improper maintenance, incorrect storage of the stroller, mechanical damage as well as natural abrasion and wear of parts (e.g. upholstery, wheels) are not covered by the warranty.
- The manufacturer warns against performing warranty repairs at unauthorized service facilities. Finding such repair or unauthorized alteration of the stroller will void the warranty.
- **The warranty card is valid provided that it has: the date of sale entered, confirmed by the Seller's company seal, the Seller's signature, type and serial number of the stroller.**
- The warranty card is valid as long as it does not contain deletions and corrections.
- The stroller manufacturer runs its paid post-warranty service.
- In matters not covered by this warranty card, the provisions of the Polish Civil Code shall apply.
- In all matters related to the warranty please contact the Seller.

27. NOTES