

MANUFACTURER / MARKETING AND ADVERTISING: MyWam Sp. z o.o.

CE



alfa*flex*

ILLUSTRATIVE PHOTO



OPERATION AND MAINTENANCE MANUAL

Edition 1 / 2024-11-07

Special needs stroller ALFA flex

THIS IS A MEDICAL DEVICE.

USE IT ACCORDING TO THE INSTRUCTION MANUAL OR LABEL.

PURPOSE OF THE MANUAL

The operating and maintenance manual is intended for persons who directly care for disabled children (child assistants - parents, guardians) who will be transported in a stroller. It is also intended for doctors and physiotherapists operating the stroller.

REMARK! Before starting to use the stroller, each User is obliged to read the content of this manual and follow it.

REMARK! In the event of any medical incident related to the presence of the ALFA flex stroller, the manufacturer must be immediately notified in writing by registered letter or e-mail with acknowledgement of receipt.

Manufacturer's contact details:

- postal address: MyWam sp. z o.o., 34 Lwowska Street, 41-500 Chorzów, Poland
- contact phone number: +48 32 733 11 31
- Email address: mywam@mywam.eu

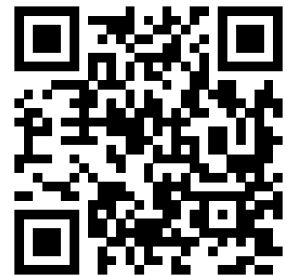

Version of the Operation and Maintenance Manual: EN, **Edition 1 / 2024-11-07**

The manual was translated using Microsoft Translator.

MyWam sp. z o.o. reserves the right to make technical and commercial changes to the content of the Operating and Maintenance Manual without prior notice. Each change will be determined by the date the statement was last updated.

The electronic version of the manual will be available on the website [of www.mywam.eu](http://www.mywam.eu)

REMARK! The photos in the Instructions for Use are for reference only and may differ from the purchased product.

MyWam sp. z o.o. has implemented a quality management system in accordance with ISO 13485 in the field of design, production and sale of class I medical devices.



ISO 13485

LL-C (Certification)



The ALFA flex stroller was developed in cooperation with



TABLE OF CONTENTS

1. PURPOSE AND INDICATIONS FOR USE.....	5
2. PLATES	5
3. SYMBOLS DESIGNATION	5
4. IMPORTANT INSTRUCTIONS AND SAFETY RULES	6
5. GENERAL CONSTRUCTION OF THE STROLLER	7
6. STROLLER FUNCTIONS	9
6.1. Unfolding the stroller frame	9
6.2. Folding the stroller frame	11
6.3. Transport lock. Putting on and taking off the transport lock	12
6.4. Front swivel wheels. Front wheels directional lock	12
6.5. Rear wheels. Assembly and removal of the rear wheels on the axle	13
6.6. Rear wheel amortization system	14
6.7. Push handle for the stroller	14
6.8. Central brake	15
6.9. Tilt Foot	15
6.10. Mechanism for attaching the backrest to the stroller frame	16
6.11. Seat depth adjustment	18
6.12. Frame adjustment for changing the seat angle	19
6.13. Backrest height adjustment	19
6.14. Frame adjustment of the backrest tilt angle	20
6.15. Footrest	21
6.16. Safety vest	22
6.17. Adjustable headrest pad	23
6.18. Adjustable thoracolumbar pads	23
6.19. Adjustable hip pads	24
6.20. Abduction and stabilization belts	25
6.21. Safety barrier	26
6.22. Adjustable canopy with window	26
6.23. Cup holder	27
6.24. Seat with gusset and side pads stabilizing the entire pelvis STABILO	27
6.25. Corset backrest STABILO	28
6.26. STABILO headrest cushion	29
6.27. STABILO Stabilizing Belt	30
7. ACCESSORIES	31
7.1. Adjustable therapeutic table (placed in place of a safety barrier)	31
7.2. Backpack	31
7.3. Shopping basket	31
7.4. Winter gloves	32
7.5. Rain cover (put on an adjustable canopy with a window)	32
7.6. Sleeping bag for legs (put on the safety barrier)	32
7.7. Mosquito net (attached to adjustable canopy with a window)	33
7.8. Sunshade umbrella	33

8.	TECHNICAL SPECIFICATIONS OF THE ALFA flex STROLLER	34
8.1.	Material composition of the stroller	34
9.	DELIVERY AND TOOLS	34
10.	ASSEMBLY AND DISASSEMBLY OF THE STROLLER	35
11.	PREPARATION FOR USE.....	35
12.	MOVING THE STROLLER	36
13.	GETTING IN AND OUT OF THE STROLLER	37
14.	CORRECT POSITION IN THE STROLLER	37
15.	USE OF THE STROLLER.....	37
16.	MOVING ON INCLINED SURFACES	38
17.	OVERCOMING THRESHOLDS OR CURBS.....	38
18.	TRANSPORT IN THE CAR AND IN OTHER VEHICLES.....	38
19.	CLEANING AND CARE	38
20.	STORING YOUR STROLLER.....	39
21.	SERVICE AND PERIODIC INSPECTIONS	39
22.	DISPOSAL.....	40
23.	COMPLIANCE WITH MEDICAL DEVICE REQUIREMENTS	40
24.	LIST OF AUTHORIZED SERVICE POINTS	41
25.	WARRANTY CARD.....	42
26.	NOTES.....	43

1. PURPOSE AND INDICATIONS FOR USE

The special needs stroller ALFA flex is a class I medical device indicated for use by those disabled children who, due to their condition, cannot walk, stand or sit independently. The product is intended for transporting and moving the above people in a sitting or lying position and for posture correction.

Clinical indications include, m.in, cerebral palsy, myelomeningocele, dystrophies, paresis, etc.

The product is intended for users with a height of 100-150 cm and a weight of up to 55 kg. The device should be used in accordance with the recommendations of the attending physician or physiotherapist.

Contraindications:

In the case of contraindications to the sitting position and/or passive upright position, the adjustment of the stroller should be consulted with a physiotherapist or attending physician.

2. PLATES

Nameplate





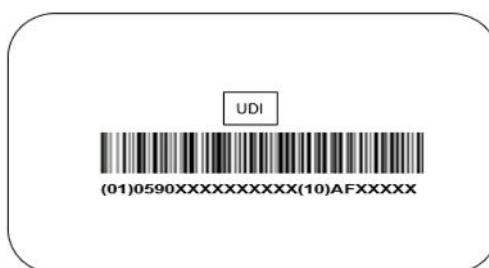



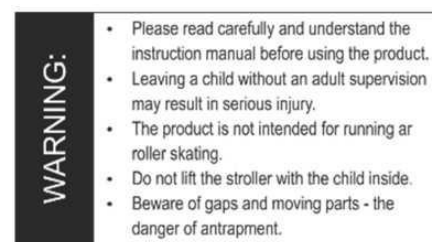

UDI code plate



Warning plate



3. SYMBOLS DESIGNATION

	Product Serial Number		Manufacturer Name
	Permitted total user weight		The product is a medical device
	Production date	 <p>DESCRIPTION "WARNING!" and symbol in this manual are used to enhance the reader's attention to the content marked with this sign. Failure to comply with the content marked with this description may pose a risk to the health and safety of the user and their companions, and may also lead to damage to the product.</p>	
	Conformity assessment mark according to applicable European regulations and directives		
	Warning about proceeding in accordance with the product Operation and Maintenance Manual		

4. IMPORTANT INSTRUCTIONS AND SAFETY RULES

- It is forbidden to use the stroller in a way for which the stroller is not intended.
- The product contains small parts that can be dangerous if swallowed by a child!
- **Due to the high adjustability of the stroller, during the angle adjustment of the seat and the angle adjustment of the backrest, it is possible to set such a position in which the child's head will be below the pelovic line. It is forbidden to use such a position, as it could lead to the danger of the child swallowing or choking.**
- It is prohibited to place additional weight on the stroller, which in particular applies to placing additional weight on the back of the backrest, e.g. a backpack or bag. This may cause the stroller to tip over and injure the user! Does not apply to original additional accessories dedicated to the ALFA flex stroller that do not exceed the permissible load. All additional elements attached to the stroller affect its stability.
- **ATTENTION!** Adjustments are made without a load (user). While using, folding and adjusting of stroller mechanisms, there may be a risk of entrapment and/or squeezing some parts of the user body/caregiver in wholes/gaps between parts.
- **ATTENTION!** Depending on the adjustments made – applies to the setting of the push handle of the stroller, backrest height adjustment, backrest angle adjustment, seat depth adjustment, seat angle adjustment, footrest angle adjustment, and footrest adjustment – then this stroller may exceed to recommended maximum dimensions.
- **ATTENTION!** When passing through doors or similar restrictions, limiting the direction of travel of the stroller, make sure that there is enough space on both sides of the stroller to prevent hands or other body parts from getting pinched, as well as to prevent damage to the stroller.
- **ATTENTION!** The temperature of the stroller may increase when the stroller is exposed to sunlight.

WARNING!



- Never leave your child unattended in a stroller, as it risks danger!
 - This product is not suitable for running, skating or roller-skating.
 - Beware of gaps and moving parts – risk of jamming.
 - Do not carry the stroller with the child inside it.
 - The stroller is packed in a plastic bag. Keep it away from infants and young children.
-
- **ATTENTION!** It is forbidden to use the stroller if the technical condition of the stroller or a single component raises doubts in the user's mind or is clearly abnormal, then it must not be used. In such a situation, it is recommended to urgently contact the Seller for advice.

5. GENERAL CONSTRUCTION OF THE STROLLER

Basic equipment



- | | |
|---|--|
| 1- Canopy with window | 17- Backrest height adjustment |
| 2- STABILO headrest cushion | 18- Hip pads |
| 3- Corset backrest STABILO | 19- Angle adjustment mechanism for the entire footrest |
| 4- Safety vest | 20- Footrest length adjustment |
| 5- Safety barrier | 21- Central brake |
| 6- Abduction and stabilization belts | 22- Rear wheels |
| 7- Seat with gusset and side pads stabilizing the entire pelvis STABILO | 23- Push handle for the stroller |
| 8- Adjustable footrest with straps | 24- Angle adjustment mechanism of the push handle |
| 9- Headrest pad | 25- Frame folding mechanism lock |
| 10- Cup holder | 26- Backrest angle adjustment |
| 11- Frame folding mechanism | 27- Backrest angle adjustment mechanism |
| 12- Transport lock | 28- Seat angle adjustment |
| 13- Seat depth adjustment | 29- Rear wheel amortization system |
| 14- Front wheels directional lock | 30- Tilt Foot |
| 15- Front swivel wheels | 31- Rear wheel quick-release mechanism |
| 16- Thoracillolumbar pads | |

Accessories



- 1- Sunshade umbrella
- 2- Therapeutic table
- 3- Sleeping bag for legs
- 4- Mosquito net

- 5- Rain cover
- 6- Winter gloves
- 7- Backpack
- 8- Shopping basket

6. STROLLER FUNCTIONS

6.1. Unfolding the stroller frame



Pull down the transport lock



Slide in the backrest

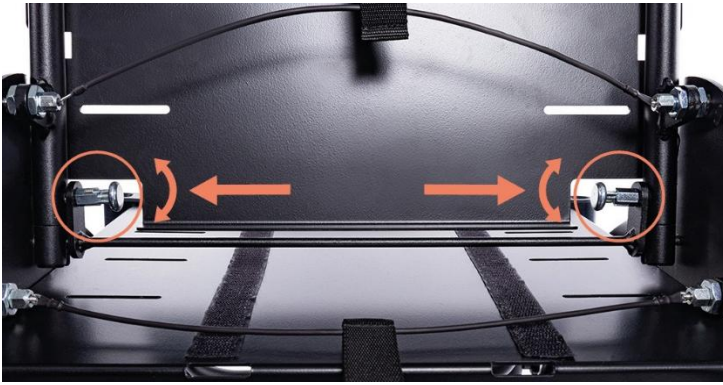

Unlocked mechanism set at the height of the holes on both sides

7

Slide the pins into the holes on both sides

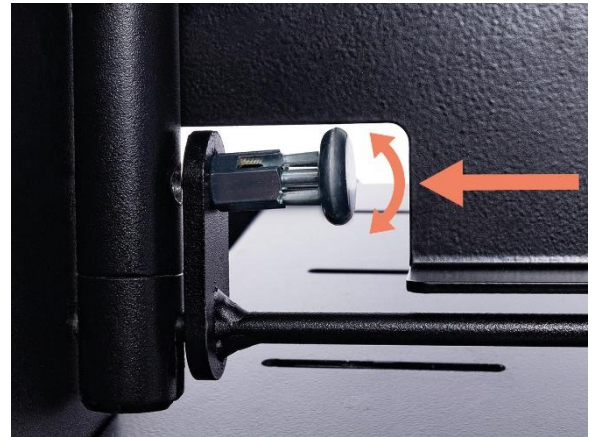
**8**

Lock the backrest attachment mechanism

**9**

Pull the handle up and adjust the backrest angle

10

6.2. Folding the stroller frame

1



2

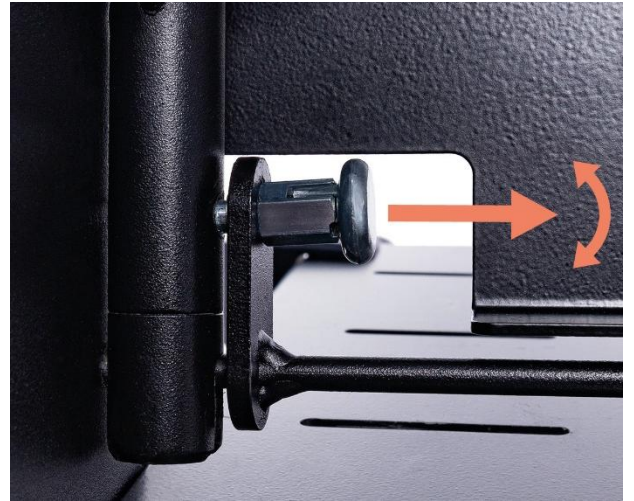

Unlock the backrest attachment mechanism

3



Lower the mechanism down

4

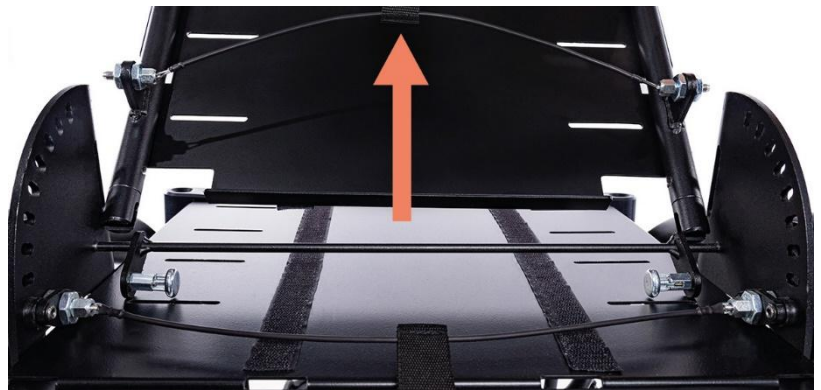

Remove the backrest

5



Press the red button

6

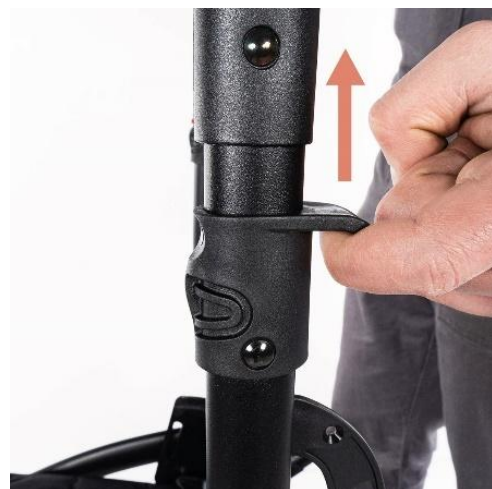

Simultaneously pull the handles on both sides of the frame upwards



Attach the transport lock

6.3. Transport lock. Putting on and taking off the transport lock



Lock applied



Removed lock

6.4. Front swivel wheels. Front wheels directional lock

Locking the front wheels



Unlocking the front wheels

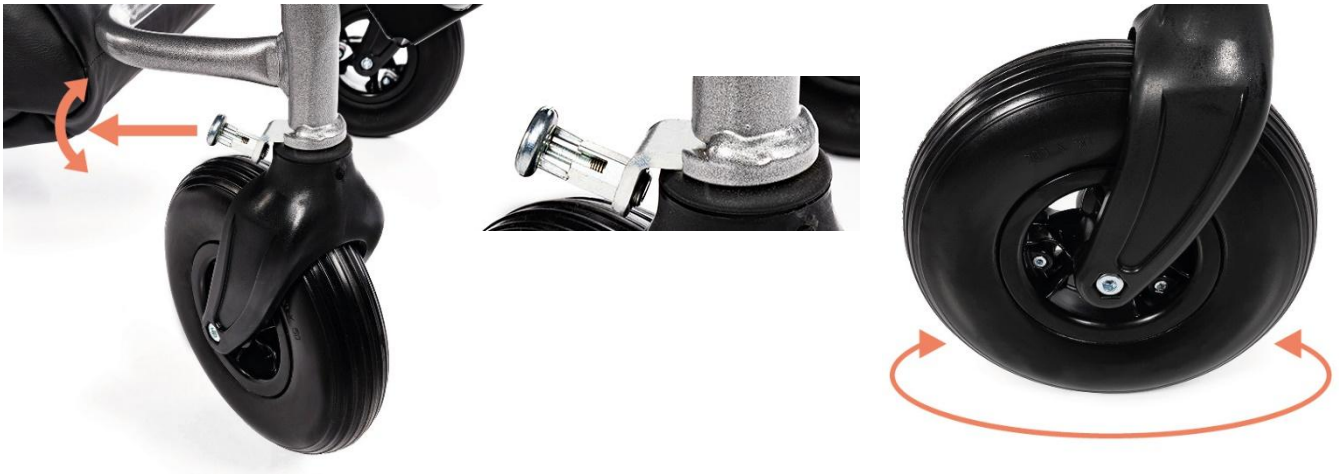

6.5. Rear wheels. Assembly and removal of the rear wheels on the axle

Wheel assembly

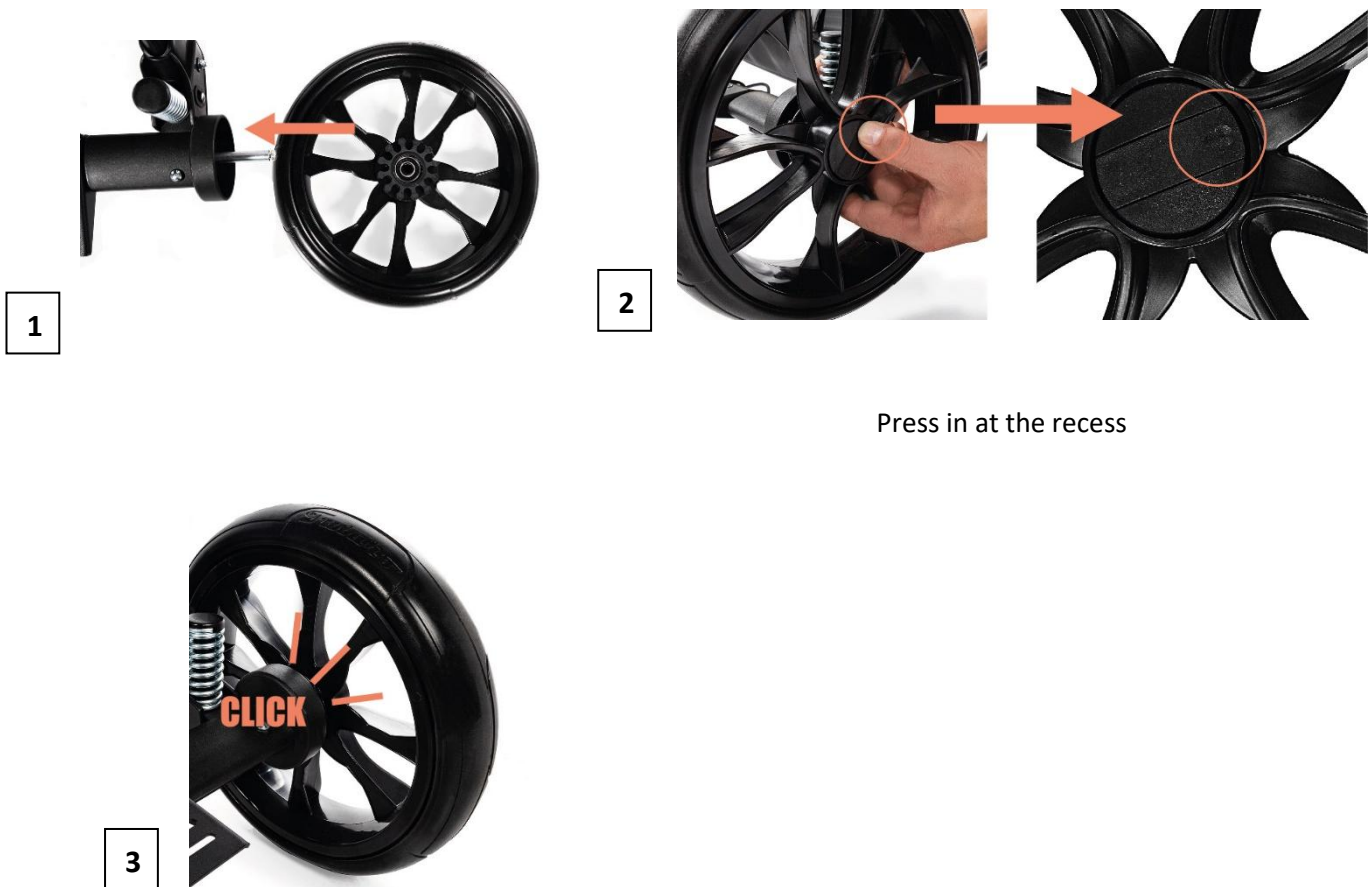

Press in at the recess

Removal of wheels



6.6. Rear wheel amortization system



Hard suspension



Soft suspension

6.7. Push handle for the stroller

Angle adjustment mechanism of the push handle



Press the buttons on both sides and change the angle of the push handle.

Angle adjustment of the push handle



6.8. Central brake



The central brake is only used to lock the wheels completely – there is no dynamic braking function.

REMARK! Regularly check the condition of the brake and remove any dirt and mud.

6.9. Tilt Foot



Using a tilt foot makes it easier to drive the stroller up small thresholds or curbs.

6.10. Mechanism for attaching the backrest to the stroller frame

Assembly the backrest to the frame



The backrest assembly mechanism is located at the back of the seat.



Slide in the backrest



Unlocked mechanism set at the height of the holes on both sides



Slide the pins into the holes on both sides

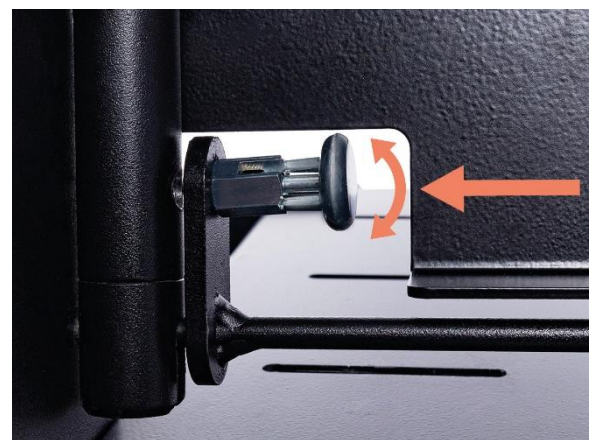

5



Lock the backrest attachment mechanism



6



Pull the handle up and adjust the backrest angle

Removing the backrest from the frame

1



2

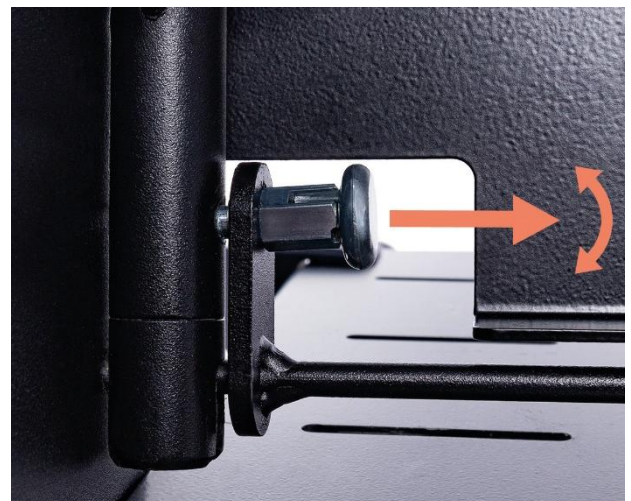

Unlock the backrest attachment mechanism

3



Lower the mechanism down

4

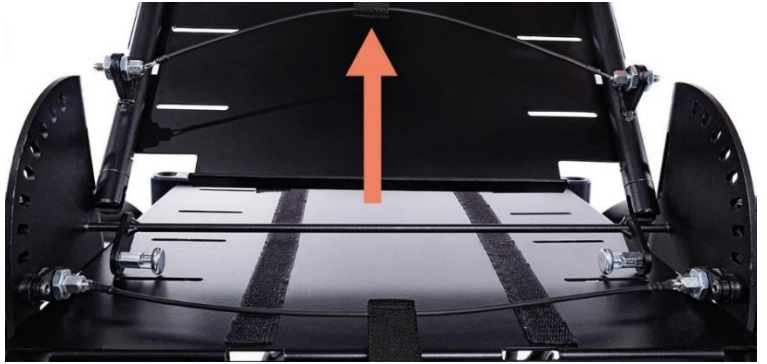

Remove the backrest

6.11. Seat depth adjustment



Minimum seat depth



Maximum seat depth

Pull the seat towards you or slide it in.



REMARK! To adjust the seat depth, use an Allen key (included).

6.12. Frame adjustment for changing the seat angle

Seat angle adjustment mechanism

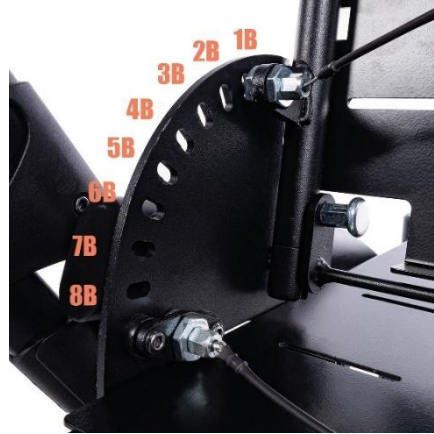

Make sure the pins have snapped on both sides of stroller.

Seat angle adjustment



6.13. Backrest height adjustment



Minimum setting backrest height



Maximum setting backrest height



Button indicating the highest backrest height



REMARK! To adjust the height of the backrest, use an Allen key (included).

6.14. Frame adjustment of the backrest tilt angle

Backrest angle adjustment mechanism

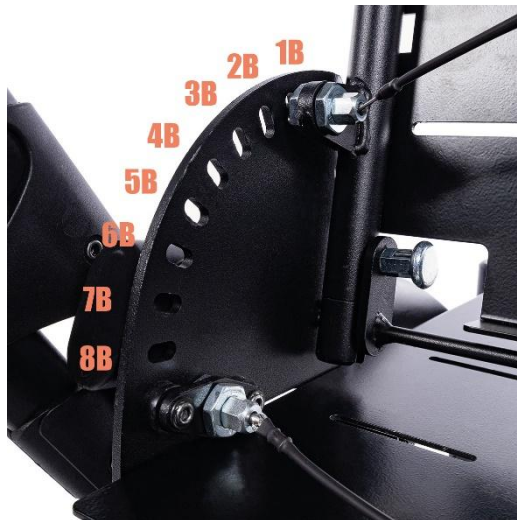
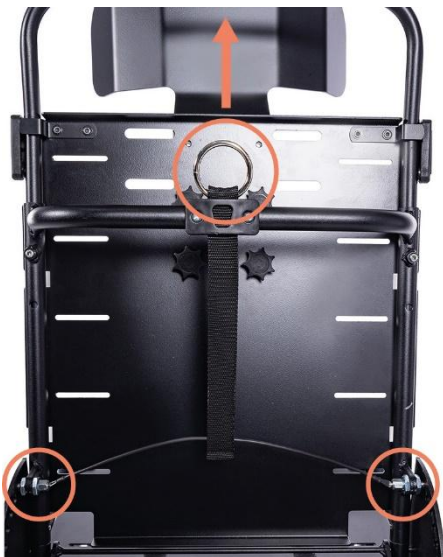

Make sure the pins have snapped on both sides of stroller.

Backrest angle adjustment



Remark! Each time you change the angle of of the backrest, you need to readjust the vest.

6.15. Footrest

Footrest height adjustment



Minimum height



Maximum height

Footrest angle adjustment



Press the buttons on both sides and change the angle of the footrest.



Remark! During transport, storage, rehabilitation, getting in and out of the stroller, the footrest plate must be folded.

6.16. Safety vest



Remark! When removing the backrest, unfasten the vest.

Remember to fasten the vest when assembling the backrest.

Assembling the vest to the stroller



Remark! Each time you change the angle of inclination of the backrest, you need to readjust the vest.

Vest assembling location on the backrest



Assembling the vest to the frame



Pull the straps through the holes and tie through the buckle on the belt.

6.17. Adjustable headrest pad



Pad height adjustment

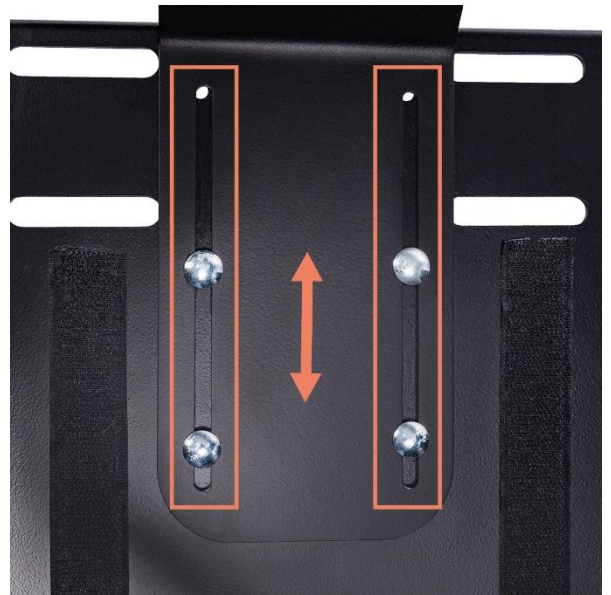

6.18. Adjustable thoracolumbar pads

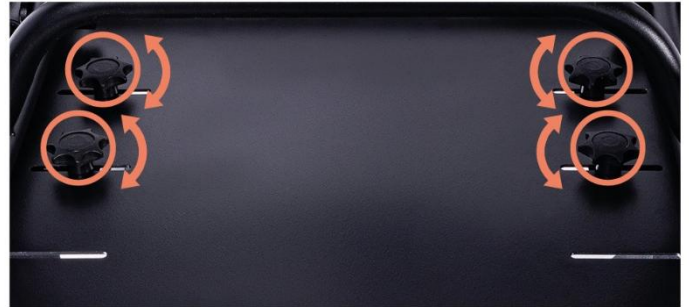
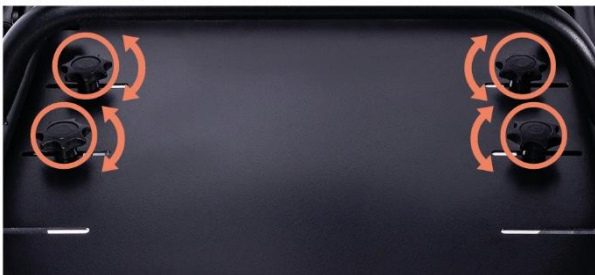

Backrest width adjustment**6.19. Adjustable hip pads****Seat width adjustment**

Seat depth adjustment

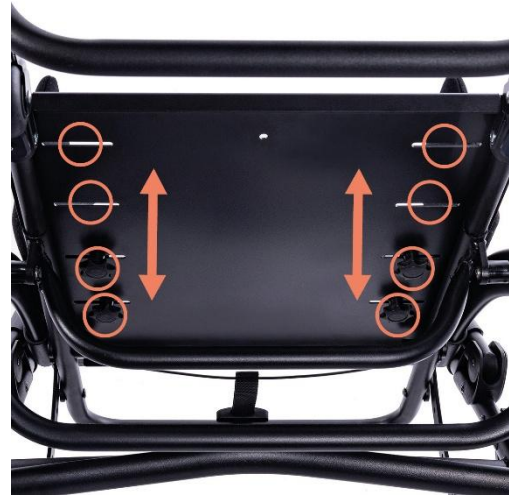

6.20. Abduction and stabilization belts



Attaching the straps to the seat

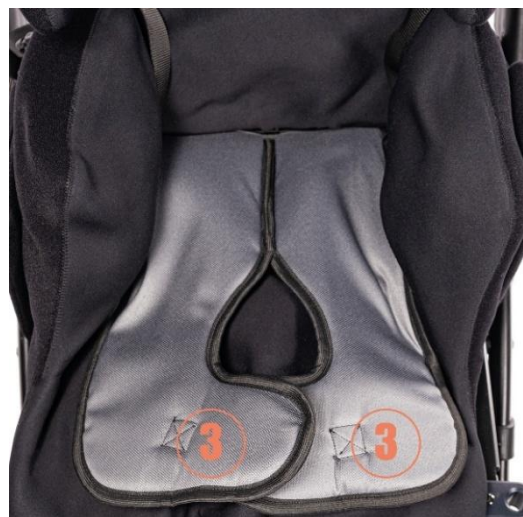

Attaching the straps to the stroller frame

6.21. Safety barrier



Press the button on both sides and slide the barrier in or out.

6.22. Adjustable canopy with window

Mechanism for assembling the canopy to the stroller frame



Slide the mount on the canopy into the mount on the stroller frame.

Removable using the red button inside the canopy mount on both sides.

Changing the size of the canopy area

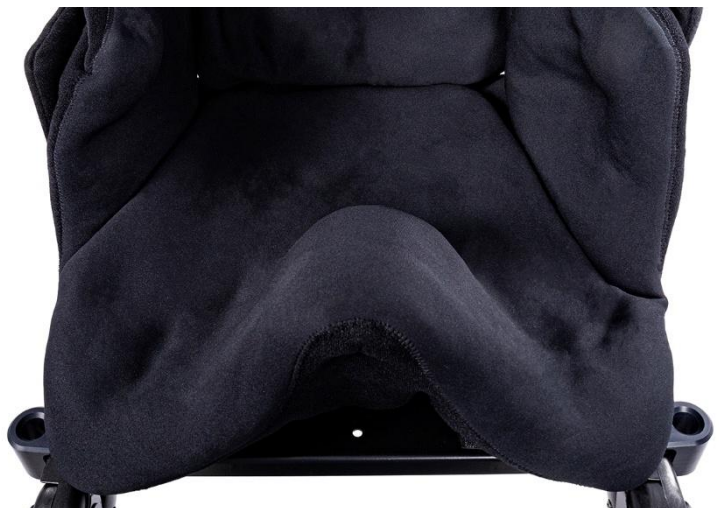

Window with mosquito net**6.23. Cup holder****6.24. Seat with gusset and side pads stabilizing the entire pelvis STABILO**

Forming the seat with a hand pump



Form the seat and suck the air out with the pump until the desired firmness is achieved.

To change the shape, screw the hose itself into the valve and wait for the seat to soften.

REMARK! Temperature change affects the hardness of the seat (temperature increase – the cushion softens, temperature drop – the cushion hardens).

REMARK! It is natural to reduce the thickness of the cushion in the initial period of use by 5%.

6.25. Corset backrest STABILO



Forming the backrest with a hand pump



Form a backrest and pump out the air until the desired hardness is achieved.

To change the shape, screw the hose itself into the valve and wait for the backrest to soften.

REMARK! Temperature change affects the hardness of the backrest (temperature increase – the pillow softens, temperature drop – the pillow hardens).

REMARK! It is natural to reduce the thickness of the cushion in the initial period of use by 5%.

6.26. STABILO headrest cushion



Forming the headrest with a hand pump



Form a headrest and pump the air out until the desired hardness is achieved.

To change the shape, screw the hose itself into the valve and wait for the backrest to soften.

REMARK! Temperature change affects the hardness of the headrest (temperature increase – the pillow softens, temperature drop – the pillow hardens).

REMARK! It is natural to reduce the thickness of the cushion in the initial period of use by 5%.

6.27. STABILO Stabilizing Belt



7. ACCESSORIES

7.1. Adjustable therapeutic table (placed in place of a safety barrier)



The maximum load is 3kg.

7.2. Backpack



The maximum load of the backpack is 2kg.

7.3. Shopping basket



The maximum load of the shopping basket is 3kg.

7.4. Winter gloves



7.5. Rain cover (put on an adjustable canopy with a window)



7.6. Sleeping bag for legs (put on the safety barrier)



7.7. Mosquito net (attached to adjustable canopy with a window)**7.8. Sunshade umbrella**

8. TECHNICAL SPECIFICATIONS OF THE ALFA flex STROLLER

length of the stroller	100-145 cm
width of the stroller	66 cm
height of the stroller	94-147 cm
total weight	26 kg
effective seat depth	30-37 cm*
seat width	20-33 cm*
backrest height	63-72 cm*
backrest width	20-33 cm*
distance between footrest and the seat / number of adjustments	33-43 cm/ 6 items
length of the stroller folded for transport	107 cm
width of the stroller folded for transport	66 cm
height of the stroller folded for transport	57 cm**
capacity of the shopping basket	3 kg
carrying capacity of a backpack	2 kg
maximum child's weight	55 kg
maximum child's height	100-150 cm
seat plane angle / number of adjustments	approx. 0°-34° / 6 positions
backrest tilt angle / number of adjustments	approx. -8.5°-62° / 8 positions
footrest angle / number of adjustments	approx. 73°-195° / 8 positions

NOTES: *) values given with the STABILO cushions, **) value given with pads

Measurement tolerance +/- 20mm, +/- 1.5kg, +/- 1°

The manufacturer reserves the right to make changes to the technical parameters.

8.1. Material composition of the stroller

Material composition of the stroller: powder-coated steel and aluminium, 100% polyester fabrics and plastic (PP, PE).

9. DELIVERY AND TOOLS

The original packaging should contain the following items:

- Folded stroller frame and backrest, footrest, wheels, canopy, pads, cup holder, safety barrier, STABILO cushions,
- User manual with warranty card,
- Additional equipment according to the order,
- 4mm Allen key,

Before use:

- a. Make sure that the package has not been damaged. If it is found that the package is damaged, then at the presence of the courier, unpack the goods and check whether none of the stroller elements hasn't been damaged.

- b. On the basis of the specification check the package content (in case of any missing elements contact your Seller).

No tools are required to assemble and disassemble the ALFA flex stroller.

To adjust the height of the backrest and the depth of the seat, use the 4mm Allen key included in the package.

10. ASSEMBLY AND DISASSEMBLY OF THE STROLLER

The product pre-packed in the original carton is already pre-assembled.

- Complete the installation by following these steps:
 - unfold the frame of the stroller and install the backrest by adjusting the following parameters:
 - enable/disable the front wheel direction lock,
 - adjust the height and angle of the handle to push the stroller,
 - set the angle of the backrest,
 - adjust the depth of the seat.
 - adjust the length of the safety vest,
 - set the footrest at the desired height,
 - install a safety barrier,
 - install a canopy with a window,
 - adjust the abduction and stabilization belts,
 - install and adjust: headrest pad, thoracolumbar pads, hip pads,
 - install and form: STABILO headrest cushion, STABILO corset backrest, seat with wedge STABILO,
 - Install the appropriate accessories:
 - backpack,
 - shopping basket,
 - sleeping bag for legs,
 - mosquito net,
 - rain cover,
 - sunshade umbrella,
 - winter gloves.

- To disassemble the stroller:

- a) remove additional equipment,
- b) remove the backrest from the stroller frame (see section 6.10),
- c) remove the rear wheels from the stroller frame,
- d) fold the frame of the stroller.

11. PREPARATION FOR USE

- Before starting to use the stroller, make sure that the child's footwear is comfortable and stabilizes the ankle joint well.
- Before starting to use the stroller, make sure that the child is not placed in the stroller without clothing covering the body in the places where it comes into contact with the upholstery of the stroller. This is to prevent abrasions of the child's body and hygienic reasons for the child.
- In the case of children with urinary incontinence problems, a special oilcloth should be placed on the seat of the stroller, which can be purchased in pharmacies or medical stores.

- In the case of using any additional aids such as cannula, drains, bags, catheters, etc. it is important to ensure that they are well protected against falling out, pulling out, clamping and do not interfere with the use of the stroller.

In order to start using the stroller properly, all the following steps must be performed:

- Place the stroller on a flat and safe surface.
- Properly unfold the stroller (see section 6.1).
- Engage the central brake.
- Make all adjustments to the stroller (see section 6. Stroller functions):
 - a) enable/disable the front wheel direction lock,
 - b) adjust the height of the push handle the stroller,
 - c) adjust the depth of the seat,
 - d) adjust the usable width of the seat,
 - e) adjust the seat tilt angle,
 - f) adjust the height of the backrest,
 - g) set the angle of inclination of the backrest,
 - h) adjust the length of the safety vest,
 - i) adjust the height of the footrest,
 - j) set the angle of inclination of the footrest,
 - k) adjust the headrest pad,
 - l) adjust the thoracolumbar pads,
 - m) adjust the hip pads,
 - n) form the STABILO headrest cushion,
 - o) form the STABILO corset backrest,
 - p) form the seat with the wedge STABILO,
 - r) adjust the abduction and stabilization belts,
 - s) adjust the canopy with the window,
 - Remove the safety barrier and therapeutical table, if these equipment is available and mounted on the stroller.
 - Prepare a safety vest, straps on the footrest and abduction and stabilizing belts to put on.
 - Place the child in the stroller and make sure that all the adjustments made earlier are suitable and safe for the child.
 - Put on the child a safety vest and straps on the footrest.
 - Put on your child other necessary equipment for the stroller, if available.

12. MOVING THE STROLLER

The best way to move a stroller is to drive it using its wheels.

In cases where this is not possible (e.g. to transport the stroller in a car), for safety reasons, the stroller can be lifted and carried with both hands after disassembling the accessories to reduce the weight to be carried and folding it.

Extreme caution should be used when moving or lifting the stroller frame. The frame must be moved after folding and installing the transport lock.

Do not use any additional equipment to carry the stroller – it may damage it.

13. GETTING IN AND OUT OF THE STROLLER

When getting on and off the stroller, place the stroller as close as possible to a stable and safe place to which the user will be transferring. After making sure that the central brake is active and the footplate is raised lifted to avoid standing on it, the user can change their position.

Do not stand on the footrest plate as there is a risk of tipping over the stroller, injury to the user and risk of damage to the product.

Make sure that when getting in or out of the stroller, the child and no other person stand on the footrest, as this may damage it and injure the user!

14. CORRECT POSITION IN THE STROLLER

For safety and health reasons, it is recommended that the user has their pelvis and back as close to the backrest as possible, in order to evenly support the spine (optimal support for all parts of the spine, so that no free space is created).

The thighs should be supported on the largest possible surface, along their entire length, which is achieved by adjusting the depth of the stroller seat, and the feet should be rested on the footrest plate, which prevents slipping, maintains optimal tension of the leg muscles and transfers some of the weight from the higher parts of the body.



REMARK! Due to the high adjustability of the stroller, during the angle adjustment of the seat and the angle adjustment of the backrest, it is possible to set such a position in which the child's head will be below the pelvic line. **It is forbidden to use such a position**, as it could lead to the danger of the child swallowing or choking.



Prohibited positioning of the stroller

15. USE OF THE STROLLER

When using the stroller, always hold the handle to push the stroller to prevent the stroller from rolling inertly. Release the central brake while holding the push handle of the stroller and push the stroller in a safe direction.

16. MOVING ON INCLINED SURFACES

Always position the stroller facing forward when climbing hills or ramps. Limit your speed on inclined surfaces and move as slowly as possible.

The person pushing the stroller must have appropriate strength to control the stability of the stroller.

Always keep in mind that the position of the center of gravity of the stroller changes when traversing uneven or sloping terrain. In such a case, be very careful and belay the stroller.

When using ramps, make sure that the ramp is suitable and the wheels of the stroller are high enough to negotiate the ramp, that the frame of the stroller will not come into contact with the ramp, and that a second person is available to assist, as there is a risk of the stroller tipping over, damaging the product and injuring the user.

17. OVERCOMING THRESHOLDS OR CURBS

When negotiating small obstacles (small thresholds, small curbs, etc.), press the tilt foot and push handle of the stroller downward and toward you with your foot to lift the front wheels of the stroller and carefully drive the front wheels onto the obstacle. Then slowly pull the push handle of the stroller upward from the ground to lift the rear wheels of the stroller and carefully drive the rear wheels on the obstacle.

18. TRANSPORT IN THE CAR AND IN OTHER VEHICLES

- Remove all accessories from the stroller and store them in a safe place. Fold the stroller and place it in the trunk.

If the dismantled stroller is not in the trunk of the car separate from the passenger compartment, the stroller frame must be carefully secured to the vehicle. For this purpose, you can use unused seat belts.

- In order to transport a stroller in other vehicles, such as trains, trams, buses, planes, ships, etc., it is necessary to ask the people in charge of transportation in these means of transport about the conditions for safe travel to the destination with a stroller and relevant requirements.



The ALFA flex stroller should not be used as a seat to transport a child in a vehicle.

19. CLEANING AND CARE

STABILO cushions can be washed in the washing machine at a temperature of up to 40°C. There is no need to use washing powder, just a fabric softener. No spinning.

The shopping basket should be washed by hand (the stain on the basket should be wiped with a damp cloth). Stains should be removed immediately after they appear on the surface of the stroller.

REMARK! Do not clean with chemicals containing solvents and bleach. The Manufacturer is not responsible for any damage caused by the use of inappropriate cleaning products.

Make sure the product is always dry before use.

If you use detergents dedicated to this type of material – follow the instructions of the agent used.



Wash at 40°



Do not bleach



Do not tumble dryer



Do not iron

20. STORING YOUR STROLLER

The clean stroller should be stored in a clean, dry and well-ventilated room, preferably at a temperature of 0-35°C. In the case of long-term storage, the steps described in point 21 "every month" should also be performed.

21. SERVICE AND PERIODIC INSPECTIONS

For safe and trouble-free use of the stroller, it is necessary to regularly and thoroughly submit it to the inspections and servicing described below.

In a situation where the stroller user is not able to carry out the above-mentioned activities on their own, they should return the stroller to a specialized stroller service point or directly to the Manufacturer, who will properly carry out the inspection and necessary servicing activities. These activities may be subject to an additional fee.

NOTE: The Manufacturer is responsible for defects or technical damage to the stroller caused only when the stroller is operated correctly. Responsibility for the proper operation of the stroller rests with the Manufacturer only if all recommendations of the Manufacturer are strictly followed.

NOTE: The Manufacturer is responsible for the proper functioning of the stroller only if original parts and original accessories are used in it.

All repairs should be carried out in specialized authorized Services (see point 24) or directly at the Manufacturer. Repairs to the stroller performed by anyone other than an authorized Service or the Manufacturer will void the warranty. The Manufacturer is not responsible for injury or damage of the product that may be a consequence of repairs performed by persons other than the authorized Service or the Manufacturer.

Service should be performed:

- **Each time before using the stroller**
 - Check the efficiency of the central brake - After activating the central brake, both rear wheels of the stroller should be locked and cannot rotate.
 - Check the attachment of structural components - Inspect all mechanisms of the stroller and its moving parts, and in particular, pay attention to: correct mounting of the backrest to the frame of the stroller, proper mounting of the wheels, proper functioning of the five-point belts, correct functioning

of the seat angle adjustment mechanism, correct functioning of the backrest recline mechanism and proper mounting of the footrest.

- Check the condition of the tires - Check that the tires on all four wheels are not damaged or worn.
- Inspection of solid frame parts, seat with backrest and footrest frame - Visually inspect the condition of the structural profiles. These components must not be damaged or cracked.
- **Every one month**
 - Cleaning of the stroller
 - Visual check of all the moving elements, bearings, adjusting mechanisms – lubricate with silicone grease.
 - Check all bolted connections for looseness.

22.DISPOSAL

Disposal and recycling: in accordance with the regulations in force in the respective country.

23.COMPLIANCE WITH MEDICAL DEVICE REQUIREMENTS

Class I Medical Device compliant with Regulation (EU) 2017/745 of the European Parliament and of the Council of 5 April 2017 on medical devices. The manufacturer has issued an appropriate declaration of conformity for the product, which can be found on the website www.mywam.eu

24. LIST OF AUTHORIZED SERVICE POINTS

POLAND

MyWam sp. z o.o.

Wiosny Ludów 91, 40-373 Katowice, Poland

phone: +48 32 733 11 31

Website: www.mywam.eu

E-mail address: mywam@mywam.eu

25. WARRANTY CARD

Series and number:

Date of purchase: - -

Stamp and signature of the seller:

.....
.....
.....

Warranty conditions

- The Seller provides the buyer with a warranty for the purchased stroller for a period of 24 months, counting from the date of purchase.
- **The buyer complaining about the stroller should deliver the stroller to the Seller in a package, clean (free of stains, additional equipment not belonging to the stroller, moisture, hair, etc.) together with the elements of the stroller protected against damage.**
- **Damage caused by insufficient protection of the forklift shipment and its components is not subject to warranty repairs.**
- The complainant cannot demand gratuity if he incorrectly labels or incorrectly insures the shipment of the forklift and its components.
- The warranty period is extended by the time the stroller is repaired.
- The activities provided for in the manual, which the user is obliged to perform on his own and at his own expense, cannot be performed as part of the warranty repair.
- Failure to use the stroller in accordance with the intended use, this instruction manual or the correct operation will void the warranty.
- Any structural changes to the truck void the warranty (in the area of change or in its entirety).
- Damage to the forklift caused by: improper operation, improper maintenance, improper storage of the stroller, mechanical damage and natural abrasion and wear of parts (e.g. upholstery, wheels) are not covered by the warranty.
- The manufacturer warns against warranty repairs in unauthorized service facilities. Finding such a repair or unauthorized modification of the stroller will void the warranty.
- **The warranty card is valid provided that it has: the date of sale confirmed by the Seller's company stamp, the Seller's signature, the type and serial number of the truck.**
- The warranty card is valid provided that it does not contain deletions or corrections.
- The manufacturer of the forklift conducts a paid post-warranty service at its headquarters.
- In matters not covered by this warranty card, the provisions of the Civil Code (Poland) shall apply.
- All matters related to the warranty and complaint of the stroller should be directed to the Seller.

26. NOTES